

DSP-DF200 Advanced Lightning Sensor

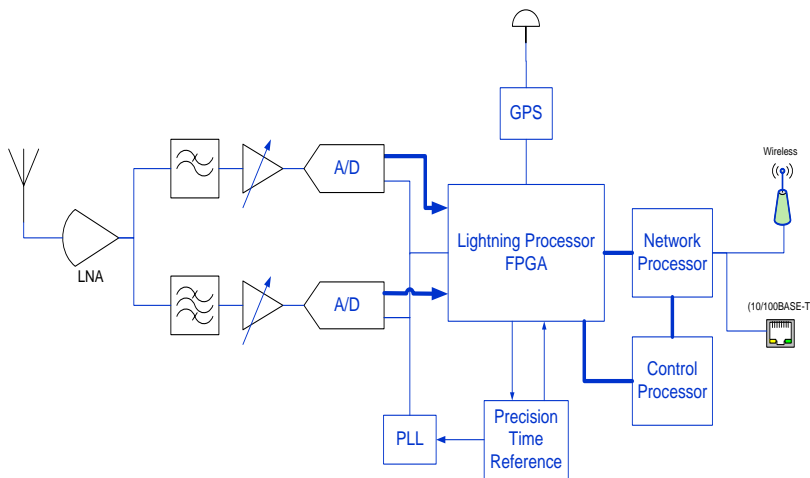

1. Ultimate Performance and Flexibility

The TOA Systems DSP-DF200 Advanced Lightning Sensor with Digital Signal Processing is designed to bring the latest technology and precision to the market today. Offering LF/VHF dual-band operation the DSP-DF200 processes lightning strokes from both cloud-to-ground (CG) and cloud lightning (CL) simultaneously. Utilizing a high sensitivity, low noise wideband receiver, state of the art digital filters and equalizers, along with precision GPS time reference, the sensor is able to characterize and categorize the lightning stroke. Once identified, the DSP-DF200 initiates a TCP/IP message to the TOA Systems Advanced Stroke Processor (ASP™) where the precise lightning location is calculated.



2. Dual Band Receiver

Featuring two independent input channels, the DSP-DF200 is uniquely equipped to specifically target both cloud-to-ground (CG) and cloud lightning (CL) strokes. Each analog input is custom designed to detect either CG or CL activity. After the analog input stages, the back-end digital signal processing provides further discrimination and precision timing, utilizing advanced pattern matching techniques to reject non-lightning activity. With programmable gain and thresholds for each channel, the receiver autonomously determines the optimal configuration based on present electrical activity.

The Low Frequency/Very Low Frequency (LF/VLF) channel of the sensor incorporates an ultra sensitive receiver front end in conjunction with precision data acquisition and timing components to capture the lightning energy from both CG and CL events. Utilizing digital integrators and filters, the lightning processor FPGA is able to characterize the stroke as either CG or CL, determine the precise time-of-arrival (TOA), amplitude, and stroke polarity. This information is buffered and sent to the network processor where it is transferred to the central Advanced Stroke Processor (ASP).

The VHF channel features higher bandwidth yet to capture even the broadest content lightning events. Narrowband channels within the band are then extracted using signal processing and the results are evaluated by the lightning processor.

To ensure both channels are always set to the optimal gain, each channel is equipped with an integral Automatic Gain Control (AGC) adjustment algorithm. So whether the lightning is 10 miles from the sensor or 200 miles away, the receiver is always tuned to maintain optimum dynamic range.

3. Advanced Digital Signal Processing

With state-of-the-art digital signal processing performance, the DSP-DF200 provides unparalleled stroke detection through the use of multistage, adjustable window, tuned filters followed by banks of matched

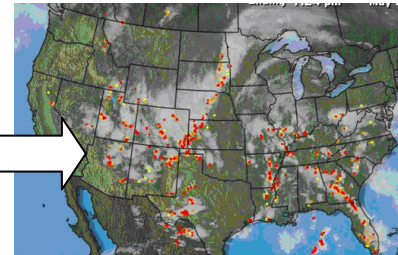
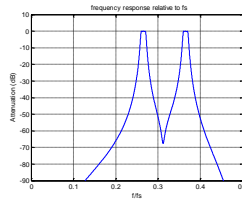
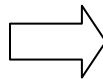

filter processing. Once the bands of interest have been isolated the signal is processed by stages of matched filters, which are able to extract strokes matching a set of predetermined characteristics. The significant amounts of signal processing gain afforded by the matched filters allow even signals below the noise floor to be extracted.

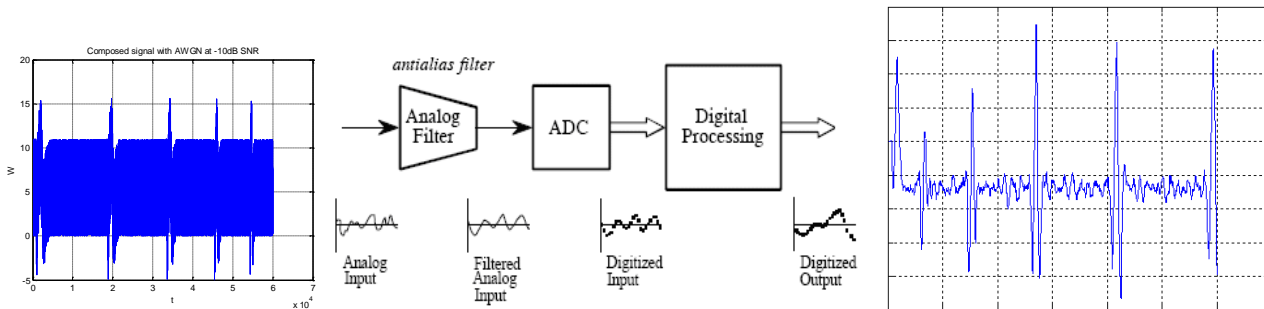

The dual band inputs are specifically designed to identify and categorize CG and CL strokes. And the utilization of high performance Field Programmable Gate Array (FPGA) technology provides True Real Time Processing (TRTP) on both channels simultaneously with zero dead time between events.

4. Configurable DSP Filtering

The Digital Signal Processing core provides powerful filtering that is configurable for each site location. This feature is particularly useful for unwanted signals such as RF Beacons, AM radio transmissions, and other in-band interference that may be present in a specific installation site. The lightning sensor performs a Fast Fourier Transform (frequency transform), identifies the interfering frequency, and then a remote update is performed to specifically target the unwanted signal.

The diagram below shows a raw unfiltered input that is corrupted by an RF Beacon on the left. This input signal is brought into a Digital Signal Processing (DSP) filter, and the final output (far right) shows the recovered lightning stroke with the interference successfully removed. By removing the noise content, the Time of Arrival is significantly more accurate, and in some cases, strokes that would otherwise be missed are processed.

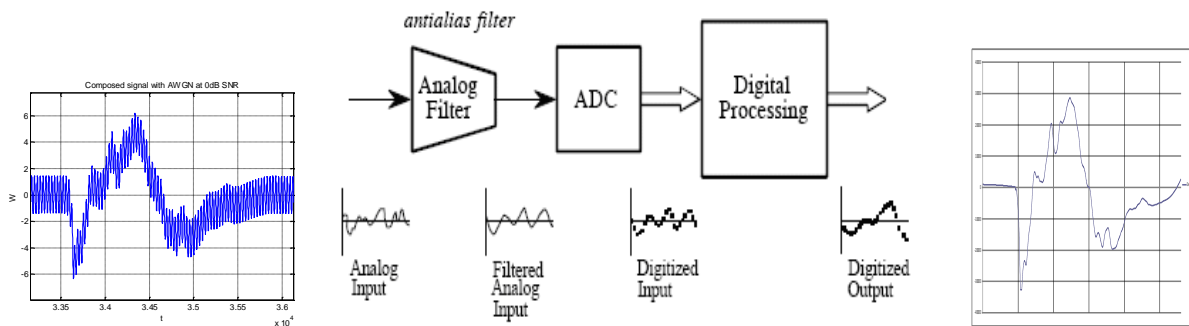

5. Ease of Use

Through an intuitive front panel display, the user is always aware of the sensor's current state. This includes a real time meter showing an electrical activity graph, GPS status, Network status, detection count, and many others. In addition, several functions are field programmable via the user-friendly front panel interface; such as the IP Address and "On Command" self test.

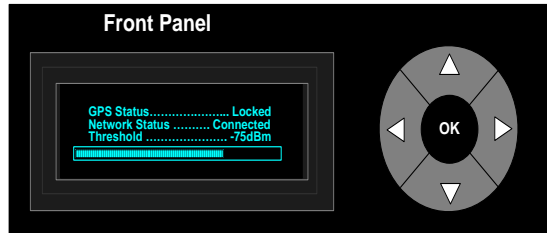

Additionally, the sensor can be configured to transmit lightning data to up to 8 Central Processing Servers simultaneously over TCP/IP. Each server can be specified using a Domain Name Server (DNS) or IP address.

6. Remote Firmware Upgrades

As new features and capabilities are developed, remote upgrades can be performed over the Ethernet connection. Each processor in the system can be easily upgraded within minutes from the central processing unit. This ensures every fielded unit has the latest technology and upgrades.

7. Built-in Diagnostics

Featuring continuous power supply monitoring, analog loopback self test, automatic timing calibration, GPS module status, and many other diagnostics, the receiver provides accurate system status and remote troubleshooting capabilities.

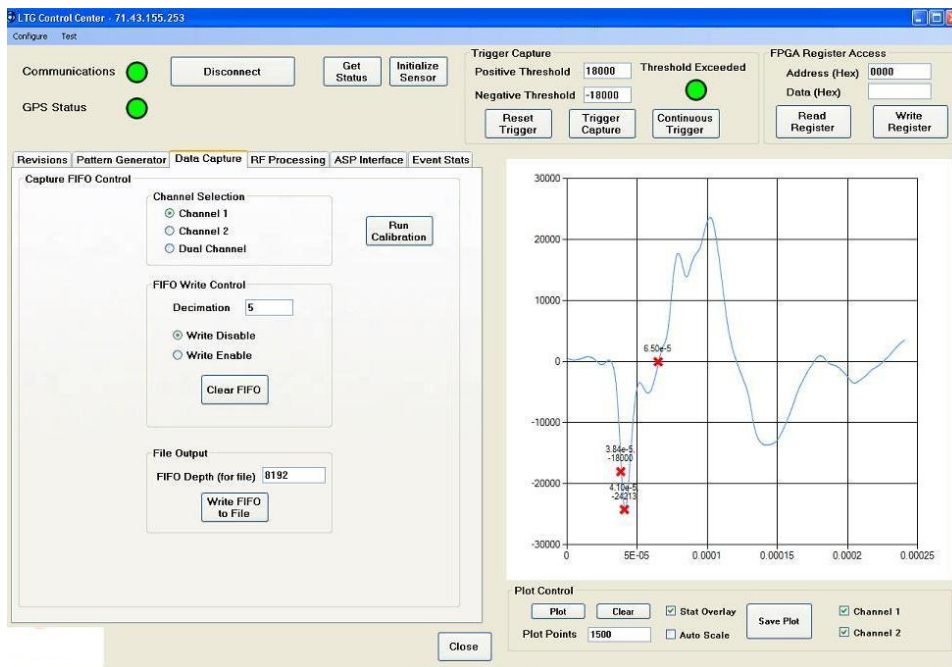

8. Operational Characteristics

Parameter	Performance
Lightning Types Detected	CG Strokes and CL Discharges (electric fields)
Location Accuracy	<250m Mean (LDN geometry dependent)
Detection Efficiency	>95% cloud-to-ground (CG) strokes >95% cloud lightning (CL) (LDN geometry dependent)
Detection False Alarm Rate	<1%
Detection Range	800 km
Sensor Baseline	20-400 km (nominal)
Sensor Site Criteria	Minimal: mounting on existing buildings is typical. (Ideal for use in mountainous terrain)
Sensor RF Bandwidth	LF/VLF - 1.5 KHz to 400 KHz VHF - High Freq Secondary channel, optional
Sensor Timing Accuracy	± 10 nsec to GPS/UTC (1 sigma)
Sensor Re-Arm Time	Zero re-arm time using real-time analysis
Waveform Digitization	Yes, optional
Points in Waveform	User selectable: 0-8191 (0-164 µSec)
Digitizing Resolution	16 bits
Digitizing Speed	50 mega-samples per second (MSPS) minimum
Power-on Diagnostics	Automatic timing calibration at power up Built in Self Test using test signal injection

9. Remote Monitoring & Control

Parameter	Performance
-----------	-------------



Sensor Sensitivity Control	Adjustable Detection Threshold and Front-End Gain settings, Automatic or user settable
Local Setup & Control	Front panel setup and status via graphics VFD and navigation keypad
Remote Configuration	Full remote firmware & FPGA- based hardware configuration and upgrade
Remote Diagnostics	Temperature and Power Supply Readings DAC settings & readings Self Test (Timing & Amplitude Calibration, and Operation) TOA factory Diagnostic Routines HTTP

10. Communications

Parameter	Performance
Serial	Asynchronous RS-232; User selectable baud rate Standard ASCII serial port
Network Port	10/100BaseT (TCP/IP, HTTP)

11. Electrical Specifications

Parameter	Performance
Power Requirements	85 - 264 VAC, 47 - 63 Hz
Power Consumption	30 Watts
Power protection (AC input)	Fused, 2.5A 20mm Quick Acting HBC

12. Mechanical

Parameter	Performance
Housing	17.0"W X 10.0"D X 1.75"H
Mounting	19" Rack mount or tabletop
Weight	5 Pounds

13. Antenna Characteristics

Parameter	Performance
Lightning (Stroke) Antenna	Vertical Whip
GPS Antenna	Active Volute
Mounting	Roof, Pole, or Tower Mount

14. Environmental Specifications

a. Outdoor Elements

Parameter	Performance
GPS antenna (Bullet III)	-40° C to 85° C
Stroke Antenna	-40° C to 85° C
Wind Speed	250 km/hour
Hail	Up to 3 cm
Rain	15 cm/hr @ 100 km/hr
Humidity	100% Condensing
Ice	25cm (survive)
Altitude	-400 to 18,000 meters
Operating Temperature	0° C to 40° C
Maximum Relative Humidity	95% Non-condensing
Storage Temperature	-30° C to +85° C

b. Indoor (DSP-DF200 Receiver w. GPS)

Parameter	Performance
Operating Temperature	0° C to 40° C
Maximum Relative Humidity	95% Non-condensing
Storage Temperature	-30° C to +85° C

15. Reliability

Parameter	Performance
Mean Time Between Failures	> 40,000 hours
Mean Time To Repair	< 1 hour

16. Key Interfaces



1 Front Panel Display

Graphics VFD (Vacuum Fluorescent Display) provides user setup and status parameters.

2 Front Panel Navigation Keys

Select and arrow keys allow intuitive control of display menus.

3 On/Off Switch

Turns off the sensor on/off.

4 20 AC inlet connector.

5 GPS Antenna

TNC connector to roof mounted GPS antenna.

6 Ethernet Connectivity

RJ-45 connector provides system 10/100BaseT Ethernet connection.

Standard RS-232C comm port.

7

8 Stroke Antenna

BNC connector to roof mounted lightning antenna

AC Inlet Connector

Serial Connectivity

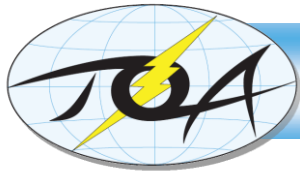

TOA Systems, Inc.
www.toasystems.com